

Neural Networks: Applications in **Industry, Business** and **Science**

BERNARD WIDROW ■ DAVID E. RUMELHART ■ MICHAEL A. LEHR

Just four years ago, the only widely reported commercial application of neural network technology outside the financial industry was the airport baggage explosive detection system [27] developed at Science Applications International Corporation (SAIC). Since that time scores of industrial and commercial applications have come into use, but the details of most of these systems are considered corporate secrets and are shrouded in secrecy. This hastening trend is due in part to the availability of an increasingly wide array of dedicated neural network hardware. This hardware is either in the form of accelerator cards for PCs and workstations or a large number of integrated circuits implementing digital and analog neural networks either currently available or in the final stages of design. An assortment of tools and development systems is provided by the manufacturers of most of these products.

Complementing the hardware are scores of commercial software packages now available. Many packages can be quickly tailored to provide low-cost turnkey solutions to a broad spectrum of applications. A very useful list containing 64 of these software and hardware tools together with their prices and the names, addresses, and phone numbers of the vendors is published in a recent issue of the magazine *PC AI* [17]. Other valuable lists of neural network tools and vendors can be found in the February issue of *Dr. Dobb's Journal* [11] and the June 1992 issue of *AI Expert*. That these lists are not complete is an indication of the rapid growth the field is presently enjoying. It is not possible in a short article to cite all of

the existing applications. The examples described herein are meant only to be representative samples.

Linear Neural Network Applications

The first successful applications of adaptive neural networks were developed by Widrow and Hoff in the 1960s. They employed single-neuron linear networks trained by the LMS algorithm [32]. Single-element and multielement linear networks are equally easy to train and have found widespread commercial application over the past three decades. A few of these applications include:

- **Telecommunications.** Modems used in the high-speed transmission of digital data through telephone

channels use adaptive line equalizers and adaptive echo cancellers. Each adaptive system utilizes a single-neuron neural network. The most significant commercial application of neural networks today is in this area.

- **Control of sound and vibration.** Active control of vibration and noise is accomplished by using an adaptive actuator to generate equal and opposite vibration and noise. This is being used in air-conditioning systems, in automotive systems, and in industrial applications.

- **Particle accelerator beam control.** The Stanford Linear Accelerator Center (SLAC) is now using adaptive techniques to cancel disturbances that diminish the positioning accuracy of opposing beams of positrons

*Gerber Baby Foods uses **neural networks** to help manage its trade in **cattle futures**... Spiegel is using software to determine which customers get their **catalogs**.*



and electrons in a particle collider. The accuracy is being held to within 2 microns in order to have a satisfactory number of collisions. The efficiency of this 3-kilometer long, billion dollar machine is being enhanced by the use of linear adaptive noise cancelling.

Multielement Nonlinear Network Applications

Unlike their linear counterparts which have a long track record of success, nonlinear multielement neural networks have begun proving themselves in commercial applications only recently. This is largely because the most useful neural network algorithm—backpropagation—did not become widely known until 1986, when it was published in Rumelhart and McClelland's two-volume PDP set [21]. Also important in the timing of the current boom in nonlinear neural network applications has been the rapid advance of computer and microprocessor performance, which continues to improve the feasibility and cost-effectiveness of computationally intensive algorithms. Although nonlinear neural networks are not currently being used as widely as linear networks, they are applicable to a much broader range of problems than their linear counterparts. Furthermore, the applications for which they are best suited often involve complex nonlinear relationships for which acceptable classical solutions are unavailable.

Successful commercial applications of nonlinear multielement neural networks in most cases currently rely on the backpropagation algorithm, with some use of backpropagation-through-time [30], radial basis functions [11], genetic algorithms [3, 24], Kohonen's Learning Vector Quantization (LVQ) [9], and a number of other algorithms. Whatever the paradigm, neural networks are currently being used

throughout business and industry to satisfy a diverse assortment of needs. Most neural network applications address problems described by one of the following three categories: 1) pattern classification, 2) prediction and financial analysis, and 3) control and optimization. Examples from each category follow:

Pattern Classification

Credit card fraud detection. Several banks and credit card companies including American Express, Mellon Bank, First USA Bank, and others are currently using neural networks to study patterns of credit card usage and to detect transactions that are potentially fraudulent [8, 10, 26]. Credit card fraud is a growing problem that threatens the entire industry. Some institutions are using home-grown software, while others are using commercial products developed by Nestor, HNC, and other companies.

Machine-printed character recognition. Commercial products performing machine-printed character recognition have been introduced by a large number of companies and have been described in the literature. Among these products are those made by Sharp Corp. [9, 26], Mitsubishi Electric Corp. [9], VeriFone Inc. [8, 9, 11, 26], Hecht-Nielsen Corp. (HNC) [11], Nestor Inc. [33], Calera Recognition Systems Inc. [11], Caere Corp. [11], and Audre Recognition Systems [11]. Sharp's Optical Character Recognition (OCR) system is used to recognize Japanese characters. It contains approximately 10 million weights and uses a variant of Kohonen's LVQ algorithm. It outperforms existing conventional systems in speed and accuracy. Mitsubishi is currently developing a similar system [9]. VeriFone's Onyx Check Reader provides an accurate, low-cost system for reading identification numbers on checks by using a custom analog neural net chip made by Syn-

aptics. Calera Recognition Systems markets a product, FaxGrabber, which automatically converts incoming faxes to text using a modified radial basis function neural network to perform OCR. Highlighting the secrecy with which many firms guard their reliance on neural network technology, Calera did not acknowledge their use of the technology (which began in 1986) until 1992 when competitor Caere Corp. announced the use of neural nets in Caere's highly successful AnyFax OCR engine. AnyFax is used in Caere's FaxMaster software and is licensed for use in other products including Delrina Technology Inc.'s WinFax Pro 3.0 fax software. Audre Recognition Systems uses a variant of the backpropagation algorithm in its OCR product, the Audre Neural Network, which not only reads standard alphanumeric but can also be trained to recognize specialized symbols on engineering drawings [11].

Hand-printed character recognition. HNC's Quickstrokes Automated Data Entry System is being used to recognize handwritten forms at Avon's order-processing center and at the state of Wyoming's Department of Revenue. In the June 1992 issue of *Systems Integration Business*, Dennis Livingston reports that before implementing the system, Wyoming was losing an estimated \$300,000 per year in interest income because so many checks were being deposited late. Cardiff Software offers a product called Teleform which uses Nestor's hand-printed character recognition system to convert a fax machine into an OCR scanner. Poqet Computer, now a subsidiary of Fujitsu, uses Nestor's NestorWriter neural network software to perform handwriting recognition for the pen-based PC it announced in January 1992 [25].

Cursive handwriting recognition. Neural networks have proved useful in the development of algorithms for

on-line cursive handwriting recognition [20]: A recent startup company in Palo Alto, Lexicus, beginning with this basic technology has developed an impressive PC-based cursive handwriting system.

Quality control in manufacturing. Neural networks are being used in a large number of quality control and quality assurance programs throughout industry. Applications include contaminant-level detection from spectroscopy data at chemical plants [11, 14] and loudspeaker defect classification by CTS Electronics [1]. According to Justin Kestelyn in the June 1990 issue of *AI Expert*, neural networks are also being used by the Florida Department of Citrus to perform orange juice purity evaluation. Applied Intelligent Systems of Ann Arbor, Mich., has built into its vision computers neural recognition features that are used for quality control in factories [11].

Event detection in particle accelerators. Research into the feasibility of using neural networks to detect notable events in high-energy particle colliders has been performed at the European Center for Particle Physics (CERN), and at a number of other research organizations [5]. Steven Kasow of CERN has reported that scientists there are using fast analog neural networks in real-time triggering systems for detectors. This permits the distillation of an enormous number of candidate events into a manageable set of "interesting" events which can be recorded on mass-storage devices and studied further. Neural networks are proving especially useful and cost-effective when used in experiments for which complex criteria are needed to differentiate between interesting and uninteresting events. Similar work is taking place at the Fermi National Accelerator Laboratory, Batavia, Ill., using Intel's high-speed analog ETANN neural network chip, according to the June 1993 issue of the *Cognizer Report* newsletter.

Petroleum exploration. Oil companies including Arco and Texaco are using neural networks to help determine the locations of underground oil and gas deposits [25].

War on drugs. Yes, neural networks have even made their debut in

the U.S. government's famous war on drugs. PC-based software emulating a multilayer neural network is being used on a daily basis at the North Carolina State Bureau of Investigation (NCSBI) to help forensic experts identify cocaine samples originating from the same batch. J. F. Casale and J. W. Watterson report in the March 1993 issue of the *Journal of Forensic Sciences* that the information helps undercover agents put together drug-related criminal cases.

Medical applications. Commercial products by Neuromedical Systems, Inc. are used for cancer screening and other medical applications [8, 9, 11, 19, 26]. The company markets electrocardiograph and pap smear systems that rely on neural network technology. The pap smear system, *Papnet*, is able to help cytotechnologists spot cancerous cells, drastically reducing false/negative classifications. The system is used by the U.S. Food and Drug Administration [6].

Prediction and Financial Analysis

Financial forecasting and portfolio management. Neural networks are used for financial forecasting at a large number of investment firms and financial entities including Merrill Lynch & Co., Salomon Brothers, Shearson Lehman Brothers Inc., Citibank, and the World Bank [3, 9, 24, 25]. Gerber Baby Foods reportedly uses neural networks to help manage its trade in cattle futures [6]. Using neural networks trained by genetic algorithms, Citibank's Andrew Colin claims to be able to earn 25% returns per year investing in the currency markets. A startup company, Promised Land Technologies, offers a \$249 software package that is claimed to yield impressive annual returns [24].

Loan approval. Chase Manhattan Bank reportedly uses a hybrid system utilizing pattern analysis and neural networks to evaluate corporate loan risk. Robert Marose reports in the May 1990 issue of *AI Expert* that the system, Creditview, helps loan officers estimate the credit worthiness of corporate loan candidates.

Real estate analysis. HNC's Areas Automated Property Valuation System [8] is being used by Foster Ous-

ley Conley to evaluate the value of residential property in California.

Marketing analysis. The Target Marketing System developed by Churchill Systems is currently in use by Veratex Corp. to optimize marketing strategy and cut marketing costs by removing unlikely future customers from a list of potential customers [8]. Likewise, Spiegel Inc. is using software created by NeuralWare Inc. to determine which customers should receive their mail order catalogs. Spiegel's director of market research expects savings of at least \$1 million per year based on increased sales and reduced catalog mailings [25].

Airline seating allocation. The Airline Marketing Assistant/Tactician developed by BehavHeuristics Inc. uses neural networks to predict passenger demand and allocate seating for carriers including Nationair Canada and USAir [8].

Control and Optimization

Electric arc furnace electrode position control. Electric arc furnaces are used to melt scrap steel. The Intelligent Arc Furnace controller systems installed by Neural Applications Corp. [8, 28] are reportedly saving millions of dollars per year per furnace in increased furnace throughput and reduced electrode wear and electricity consumption. The controller is currently being installed at furnaces worldwide.

Semiconductor process control. Kopin Corp. has used neural networks to cut dopant concentration and deposition thickness errors in solar cell manufacturing by more than a factor of two [9].

Chemical process control. Pavilion Technologies has developed a neural network process control package, Process Insights, which is helping Eastman Kodak and a number of other companies reduce waste, improve product quality, and increase plant throughput [4, 8, 9, 11, 12]. Neural network models are being used to perform sensitivity studies, determine process set points, detect faults, and predict process performance.

Petroleum refinery process control. Texaco's Puget Sound Refinery, which processes 120,000 barrels of

oil a day, has integrated neural networks into the plant's process control systems. As described in the June 1990 issue of *AI Expert*, one of these networks is used in the control of a debutanizer, a system which separates hydrocarbons according to their molecular weights. This requires precise monitoring of temperatures, pressures, and flow rates. The 17-hour batch cycle subjects the process to constant instability. A neural network has been built and trained to help ensure product quality during periods of change and instability. The seven-input, two-output network, which was trained with roughly 1,500 data samples, is usually able to correct errors in the control parameters before they appear. A feedback mechanism helps reduce unexpected errors that do occur.

Continuous-casting control during steel production. A neural control system is in operation in Japan at plants owned by Fujitsu Ltd. and Nippon Steel Corp. The system has reduced costs by several million dollars a year by eliminating the damage and downtime caused by "breakout," when imperfect control allows spillage of molten steel [9, 26, 30]. The system uses a feedforward network trained by backpropagation to detect breakout before it occurs, allowing corrective measures to be taken. The control system has been operating since early 1990.

Food and chemical formulation optimization. Neural networks are used to optimize formulations at the Glidden Co., the Lord Corp. [7], and at M&M/Mars. Researchers at the first two companies report success using AI Ware's CAD/Chem package to search for improved chemical formulations. CAD/Chem has been used by Lord Corp. in the process of formulating a new adhesive product [7] by an iterative search technique.

Nonlinear Applications on the Horizon

A large number of research programs are developing neural network solutions that are either likely to be used in products in the near future or, particularly in the case of military applications, that may already be incorporated into products,

albeit unadvertised. This category is much larger than the foregoing, so we present here only a few representative examples

Missile guidance and detonation. David Andes at the U.S. Naval Air Warfare Center, China Lake, Calif., has worked for several years using analog neural networks and the MR111 algorithm [2] in missile guidance and other military applications [26]. He has found that when fast decisions are required, neural networks have enormous advantages over conventional methods.

Fighter flight and battle pattern guidance. Defense contractors have apparently developed software using neural networks to integrate multi-source data for flight and battle pattern guidance of Lockheed's YF-22 Advanced Tactical Fighter based on real-time predictions of the imminent actions of an enemy aircraft. It is unclear, however, if such a system is operational [24].

Optical telescope focusing. Neural networks can be used to compensate for atmospheric disturbances by adaptively deforming mirror elements in response to atmospheric activity that can blur images. In strategic defense initiative-related work, Lockheed Missiles and Space Co. has developed a proprietary neural microchip that drives an adaptive focusing system for laser/mirror systems. This allows relatively small telescopes to rival much larger and more expensive ones. Colin Johnson reports in the November 19, 1990 issue of the *Electronic Engineering Times* that the first generation of the system had 69 piezoelectric actuators mounted on the back of the mirror to adjust it to the desired shape. Experiments with a similar idea utilizing a multiple mirror telescope are also described in the literature [22].

Vehicular trajectory control. Neural networks can be used to solve highly nonlinear control problems. A two-layer neural network containing 26 adaptive neural elements has learned to back up a computer-simulated trailer truck, even when initially "jackknifed." The neural net was able to learn of its own accord to do this, regardless of initial conditions. Experience gained with the truck backer-upper should be appli-

cable to a wide variety of nonlinear control problems [15].

Automotive applications. Ford Motor Co., General Motors, and other automobile manufacturers are currently researching the possibility of widespread use of neural networks in automobiles and in automobile production. Some of the areas that are yielding promising results in the laboratory include engine fault detection and diagnosis, antilock brake control, active-suspension control, and idle-speed control. General Motors is having preliminary success using neural networks to model subjective customer ratings of automobiles based on their dynamic characteristics to help engineers tailor vehicles to the market.

Electric motor failure prediction. Siemens has reportedly developed a neural network system that can accurately and inexpensively predict failure of large induction motors [26]. The system achieves 80% to 90% overall failure prediction accuracy in comparison to 30% achieved by the best conventional techniques. The predictor will be integrated into Siemens's existing Advanced Motor Master System (SAMMS) controller.

Speech recognition. The Stanford Research Institute (SRI) is currently involved in research combining neural networks with hidden Markov models (HMM) and other technologies in a highly successful speaker-independent speech recognition system. The technology will most likely be licensed to interested companies once perfected.

Mass spectra classification. Bo Curry of Hewlett-Packard Labs collaborated with David Rumelhart on the design of a feedforward neural network to classify low-resolution mass spectra of unknown compounds according to the presence or absence of 100 organic substructures. Described in HPL Technical Report 90-161, 1990, the neural network MSnet was trained to compute a maximum-likelihood estimate of the probability that each substructure is present. MSnet classifies mass spectra more reliably than other methods reported in the literature, is much faster than the standard nearest-neighbor techniques, and because of the probabilistic interpre-

*Many neural net applications are under development
in the **telecommunications industry**
for solving **control** problems.*



tation of the classification output, can readily be combined with other information sources.

Biomedical applications. Neural networks are rapidly finding diverse applications in the biomedical sciences. They are being used widely in research on amino acid sequencing in proteins, nucleotide sequencing in RNA and DNA, ECG and EEG waveform classification, prediction of patients' reactions to drug treatments, prevention of anesthesia-related accidents, arrhythmia recognition for implantable defibrillators, patient mortality predictions, quantitative cytology, detection of breast cancer from mammograms, modeling schizophrenia, clinical diagnosis of lower-back pain, enhancement and classification of medical images, lung nodule detection, diagnosis of hepatic masses, prediction of pulmonary embolism likelihood from ventilation-perfusion lung scans, and the study of interstitial lung disease.

Drug development. One particularly promising area of medical research involves the use of neural networks in predicting the medicinal properties of substances without expensive, time-consuming, and often inhumane animal testing [29]. For cancer drug screening, this has been accomplished by testing the effects that a group of 134 known drugs have on the growth of cultures of 60 types of human tumor cells. These profiles were then applied to a feedforward neural network simulated using NeuralWare's Professional II/PLUS software package and trained by backpropagation to classify each drug by mechanism of action. Cross-validation studies showed this method to be surprisingly accurate. The profiles of prospective drugs with unstudied medicinal properties could then be applied and classified by the network. More extensive tests would be performed only on the small proportion of prospective drugs placed by the network

in classes thought to be useful or interesting.

Control of copiers. The Ricoh Corp. has successfully employed neural learning techniques for control of several voltages in copiers in order to preserve uniform copy quality despite changes in temperature, humidity, time since last copy, time since change in toner cartridge, and other variables. These variables influence copy quality in highly nonlinear ways, which were learned through training of a backpropagation network. In order to improve generalization and reduce the size of the networks in copiers, Ricoh employed a sophisticated network-pruning method, which they call Optimal Brain Surgeon, which indeed led to smaller and more accurate networks.

More Detailed Descriptions of Selected Applications

The following subsections describe in greater depth a group of applications selected from the preceding summary. They all use some form of the delta rule or the backpropagation algorithm for adaptation and learning. The fields of application are highly diverse, but the learning processes are remarkably similar.

The telecommunications industry. Many neural network applications are under development in the telecommunications industry for solving problems ranging from control of a nationwide switching network to management of an entire telephone company. Other applications at the telephone circuit level turn out to be the most significant commercial applications of neural networks in the world today. Modems, commonly used for computer-to-computer communications and in every fax machine, have adaptive circuits for telephone line equalization and for echo cancellation. Adaptivity is needed because each telephone line has its own individual character-

istics, and these characteristics change over time.

Echo on telephone lines, which would normally be tolerated with speech, is devastating to high-speed data transmission. Echo cancelling solves the problem by detecting the echo and adding an equal and opposite signal to the return path. The cancelling signal is generated by an adaptive transversal filter whose coefficients (weights) are automatically adjusted by the LMS algorithm of Widrow and Hoff [32], also known as the delta rule in the field of neural networks. The adaptive filter makes use of what amounts to a single neuron. The first echo cancellers were developed at AT&T Bell Labs in the 1960s by M. M. Sondhi and his colleagues. Today they are everywhere.

The first application of adaptive techniques in telecommunications was telephone line equalization by Robert W. Lucky at AT&T Bell Labs. Telephone channels, radio channels, and even fiber-optic channels can have nonflat frequency responses and nonlinear phase responses in the signal passband. Sending digital data at high speed through these channels often results in a phenomenon called "intersymbol interference," caused by signal pulse smearing in the dispersive medium. Equalization in data modems combats this phenomenon by filtering incoming signals. A modem's adaptive filter, by adapting itself to become a channel inverse, can compensate for the irregularities in channel magnitude and phase response.

The adaptive equalizer in Figure 1 consists of a tapped delay line (a transversal filter) with a single adaptive neuron connected to the taps. Deconvolved signal pulses appear at the weighted sum, which is quantized to provide a binary output corresponding to the original binary data transmitted through the channel. The LMS algorithm is used to adapt the weights.

Figure 2a shows the analog response of a telephone channel carrying high-speed binary pulse data. Figure 2b shows an "eye" pattern, which is the same signal after going through a converged adaptive equalizer. Equalization opens the eye and allows clear separation of +1 and -1 binary data pulses.

Active control of sound and vibration. A new area of application for adaptive and learning systems to active control of noise and vibration, has been developing during the last 5 or 10 years. Passive control of noise would make use of thick walls and sound-absorbing materials and coatings, while passive control of vibration would make use of shock absorbers, damping materials and structures, and other methods of isolating and snubbing vibration. Active sound control uses adaptive techniques to generate antisound (equal and opposite) to cancel noise in a space or volume. Active vibration control uses adaptive techniques to

generate vibration to cancel existing vibration.

Active vibration control in a car is seen in the following example: Engine vibration coupling into the chassis through the four supporting engine mounts is cancelled by transducers shunting the engine mounts, which are driven so that equal and opposite forces are applied to the chassis. The transducer signals come from a set of adaptive filters, each utilizing a single neuron adapted by means of the "filtered-X" LMS algorithm [32].

Several companies have developed "electronic mufflers" which can replace the conventional passive mufflers in automobiles [23]. This is an example of active noise control. A tachometer on the engine generates pulse trains at the cylinder-firing rate. The tachometer signal is adaptively filtered, amplified, and fed to a small loudspeaker in the exhaust system. The loudspeaker generates anti-sound. The adaptive filter utilizes a single neuron that learns with the filtered-X LMS algorithm. The result is an engine that is at least as quiet as one with a conventional muffler. Additionally, the engine "breathes"

more easily, resulting in more horsepower and better fuel efficiency. As described by Randy Barrett in the August 12, 1993, issue of *Washington Technology*, Noise Cancellation Technologies (NCT) in a joint venture with Walker Manufacturing currently has electronic mufflers under test in New York City and Montreal bus fleets, where they have already demonstrated a 2.5% improvement in fuel economy. According to the October 28, 1992, issue of the *Electronic Engineering Times*, the first production vehicles with the NCT-Walker muffler should be available in 1996. A number of other automotive applications of the filtered-X LMS algorithm can be found in the proceedings of a conference on active control of sound and vibration held at Virginia Tech in April of 1991.

Active noise cancellation is also being developed to reduce noise problems caused by heating and air-conditioning equipment, vacuum cleaners, emergency vehicle sirens, aircraft, lawn mowers, and industrial equipment. NCT now markets a \$99 noise-cancelling headphone called NoiseBuster.

Beam control at the Stanford Linear Accelerator Center. The Stanford Linear Accelerator Center (SLAC) is a complex of particle accelerators operated by Stanford University for the U.S. Department of Energy. Physicists from all over the world design and perform experiments there, 24 hours a day, 7 days a week. A 3-kilometer-long linear accelerator fires both positrons and electrons into the circular arcs of a collider. A major challenge involves controlling the positions of the electron and positron beams in the collider to within 2 microns in spite of unpredictable disturbances that take place in the accelerator (due to changes in temperature, barometric pressure, vibration, sensor noise and so forth). Collisions must occur in order for the physicists to do their work, and the probability of collisions depends on the accuracy of positioning the opposing positron and electron beams.

The linear accelerator is divided into 20 sections. Each section has beam position sensors and control

Figure 1. Adaptive channel equalizer with decision-directed learning

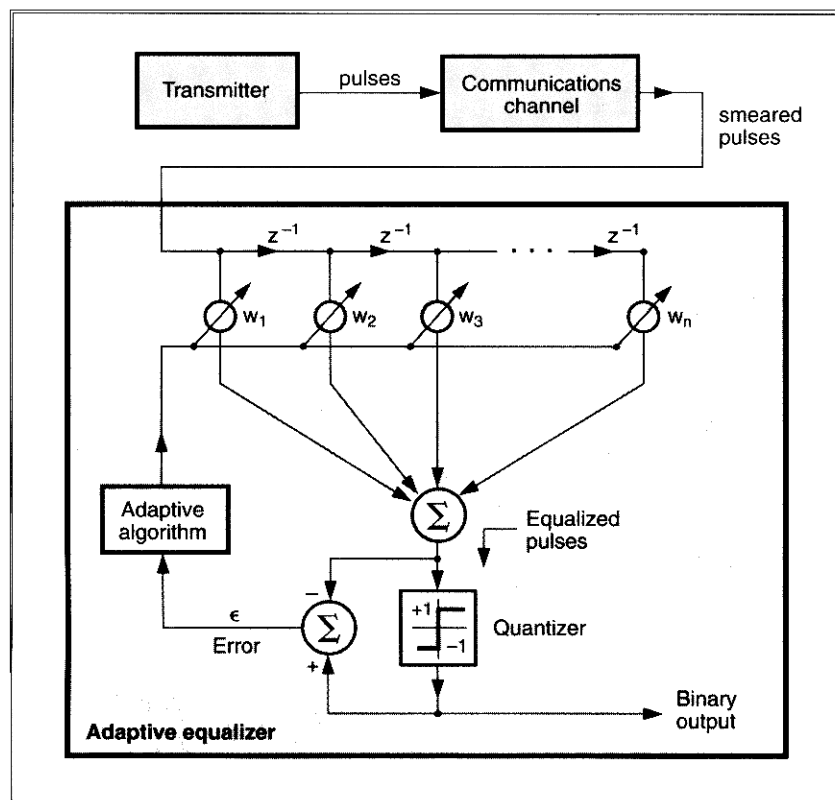

magnets to deflect the beam. Conventional feedback systems are used with each section for beam control, and they greatly reduce the variations in the beam position. Nonetheless, the system could not achieve the required accuracy without adaptive noise cancelling. Each section was equipped with a multi-input multi-output (MIMO) adaptive canceller, eight inputs, and eight outputs. This is equivalent to a neural network without nonlinearity. Adaptation was done by a MIMO form of the LMS algorithm. Prior to the installation of the new system, operators at the accelerator would frequently make frantic late-night phone calls for help in recovering from a problem. The system has been so robust and stable in the six months since the adaptive solution was implemented that the late-night phone calls have ceased, and no significant problems have occurred. (This work was performed by Thomas M. Himel of SLAC.)

The truck backer-upper. Vehicular control by artificial neural networks is a topic that has generated widespread interest. At Purdue University, tests have been performed using neural networks to control a model helicopter [16]. In a much larger project, a full-sized self-driving van named ALVINN (Autonomous Land Vehicle In a Neural Network) complete with video camera "eyes" and an onboard "brain" made from four workstations has been developed and built at Carnegie-Mellon University [18]. ALVINN learned to drive by watching humans drive and can drive long distances at normal highway speeds, negotiating through traffic without human intervention. The system is not yet perfect, of course, so when ALVINN drives, a human is always present to take over the controls if something goes wrong.

We now consider a system less complicated and more easily described than ALVINN—that of a neural network which has learned to steer a computer-simulated truck and trailer while backing to a loading platform. A solution to this highly nonlinear control problem was obtained by self-learning. The inputs to the two-layer network are "state" variables: the angle and position of

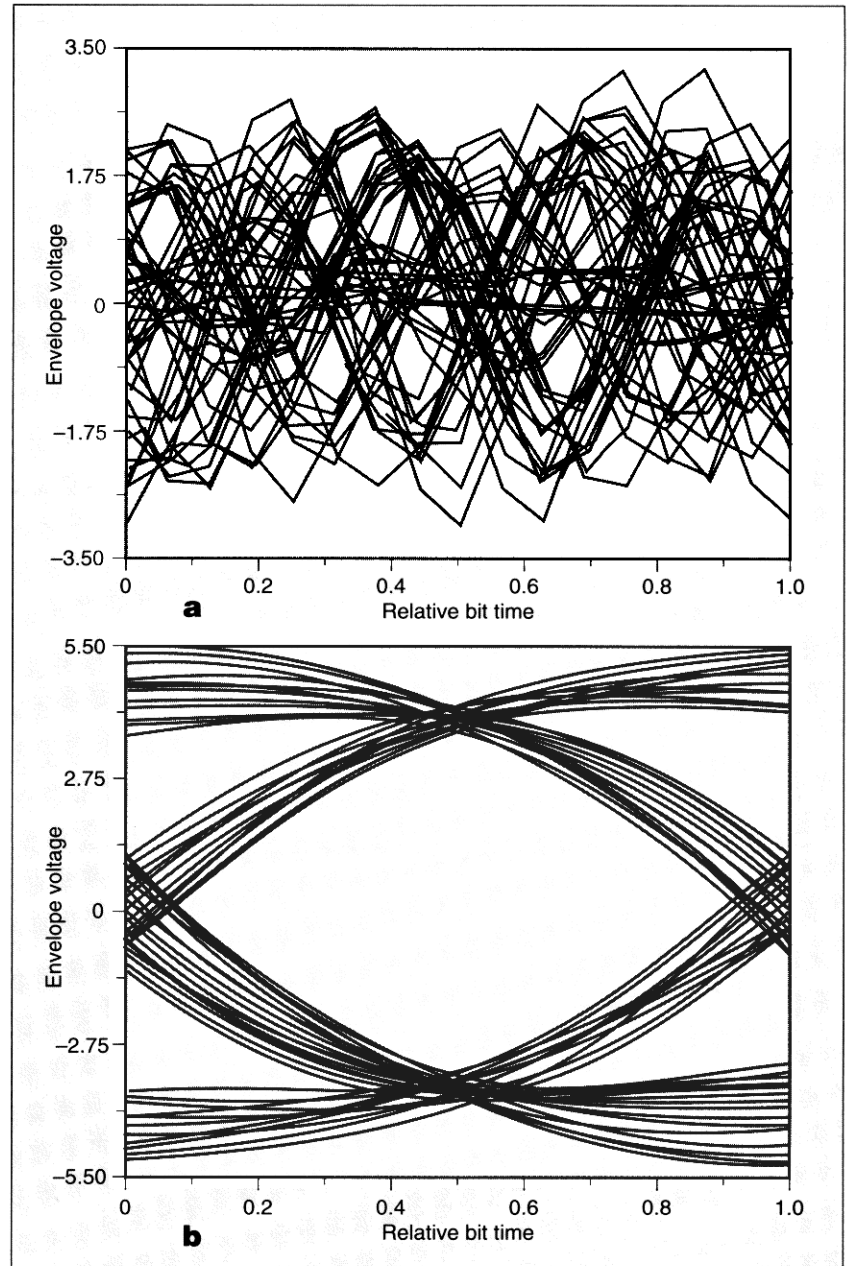

the rear of the trailer and the angle of the cab (see Figure 3). The output of the neural network is the angle of the steering wheel. The work was done by Nguyen and Widrow [15]. The learning algorithm they used, which is based on the famous backpropagation algorithm [21, 30, 31], is called backpropagation-through-time.

The truck was only allowed to back up. Backing was done as a sequence of small steps. On the scale of a real "18-wheeler," each step would be a distance of approximately one meter. The truck backs from its initial posi-

Figure 2. Eye patterns produced by overlaying cycles of the received waveform: a. before adaptive equalization; b. after adaptive equalization.

tion until it hits something and stops. The desired final state of the system involves having the rear of the trailer parallel to the loading platform and positioned at its center. The actual final state is compared with the desired final state, and the difference is a state error vector. After each backing-up sequence is completed, the final error vector is used to mod-

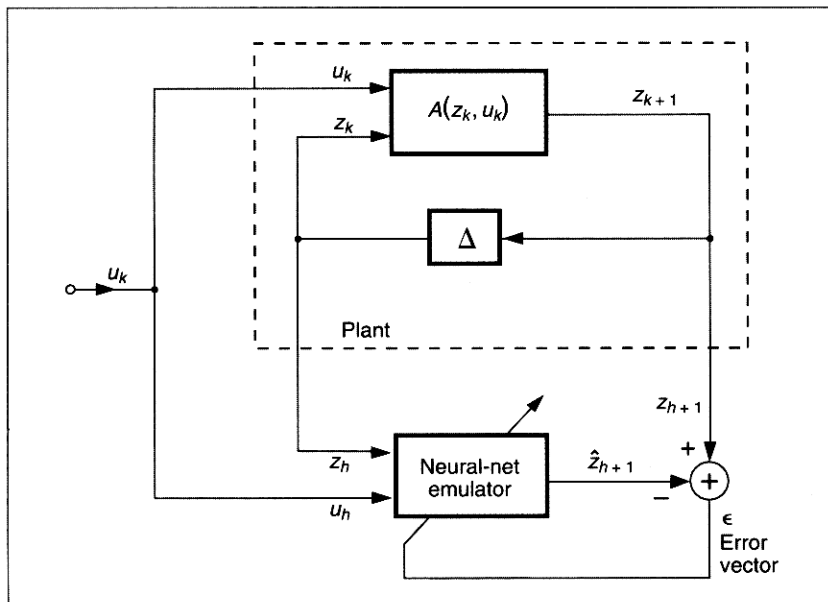
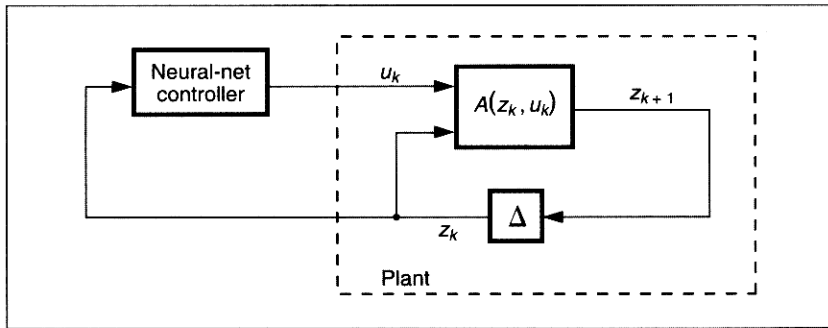
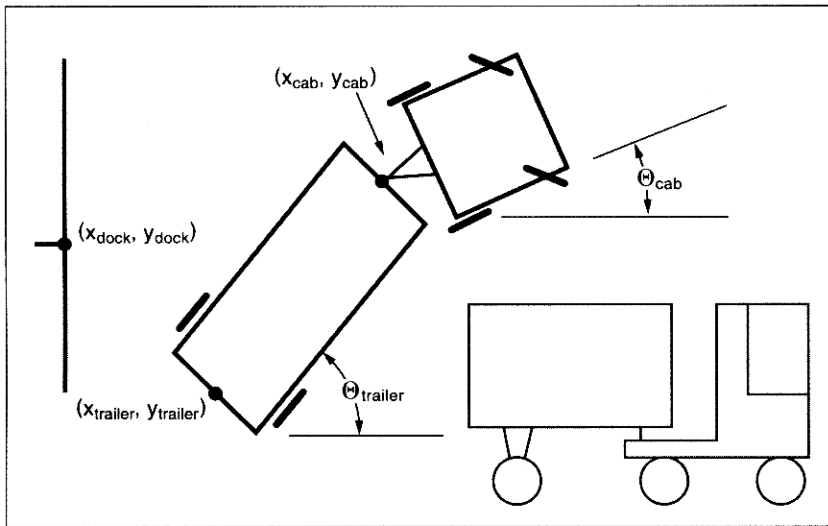

Figure 3. Truck, trailer, and loading dock

Figure 4. Plant and controller

Figure 5. Training the neural net plant emulator

if the controller weights, so that if the truck is placed in the same initial position and allowed to retry the backup sequence, the new final-state error will have a smaller magnitude than before.

Figure 4 is a diagram of the neural

net controller steering the truck—a controller governing a “plant” represented by the truck kinematics. To train the controller, an emulator of the truck kinematics is needed. This is a two-layer neural network trained by backpropagation as shown in Figure 5 to produce the same output states as the plant when both the emulator and plant have the same driving function.

The controller is a two-layer neural network trained as shown in Figure 6. The initial position or state of the truck, z_0 , is applied to the controller, which generates a single output, the steering wheel angle. Using this steering signal, the truck backs up a step. The process of using the controller to set the steering angle, and then backing a step is repeated until either the truck hits something or the number of time steps exceeds a predetermined constant.

Backing from state to state is represented by signals going through the layers of a neural net. The controller and emulator are each composed of two layers of adaptive neurons. Every backing step corresponds to signals going through four layers. By “unrolling” the control system’s feedback loop, the whole backup sequence can thus be represented as the forward propagation through a giant feedforward neural network containing a number of layers equal to four times the number of time steps. In a process called backpropagation-through-time, the final-error vector is backpropagated through all the layers of this composite network.

After each backup sequence, the backpropagation-through-time algorithm finds a gradient of the squared positional error of the truck’s final state with respect to the weights of the controller. This gradient is used to update the controller’s weights by stochastic gradient descent.

Once learning is complete, the truck is able to back up satisfactorily from almost any initial position, even “jackknifed,” and even from initial positions that were not previously encountered during training. The controller’s ability to react and respond reasonably to new positions is an example of generalization. An illustration of the functioning of an already-trained system is shown in

Figure 7. This is a laboratory exercise that could, in the future, have implications for vehicle control. Large American trucking companies are seriously exploring this technology. At the present time, the truck backer serves as a visual demonstration of the capabilities of nonlinear networks. This demonstration helped motivate development of the Intelligent Arc Furnace controller described next.

Steel making. An electric arc furnace is used to melt and process scrap steel. The heat energy comes from a three-phase power line of rather massive capacity (often 30 megawatts or more—enough electrical power for a city of 30,000 people). The three-phase line connects to a bank of step-down transformers to supply current for three electrodes that stick down into the furnace. The electrodes are made of graphite, are about one foot in diameter, and are about 20 feet long. Three independent servos control the depth of the electrodes into the furnace.

When starting a new “heat,” scrap steel is loaded into the furnace, and the servos are activated to drive the electrodes down toward the scrap pile. When an arc is first struck, sparks fly, and the noise is deafening. One’s first impression of this is that it is like Dante’s inferno.

Because the cost of installing and operating a large arc furnace is so great, even small changes in efficiency have a tremendous impact on economics. The motivation for the development of “intelligent control” is clear. In this section we describe the Intelligent Arc Furnace controller, invented by Bill Staib of Neural Applications Corp. [28]. The figures in this section were supplied by the inventor.

Figure 8 shows an arc furnace, its three-phase power system, and instrumentation that provides signals useful for the control of the electrode servos. Currents and voltages in the system are sensed, digitized, and fed to a 486 PC that implements the neural control system. Numerical processing is performed by an 80-MFLOP Intel i860 microprocessor. A microphone placed near the furnace provides the computer with the

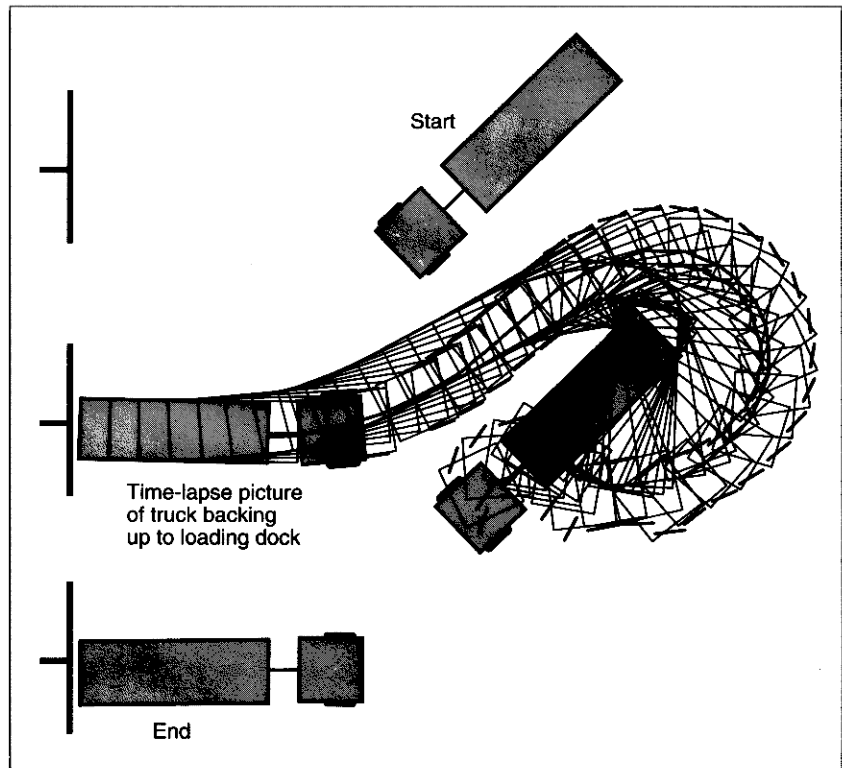
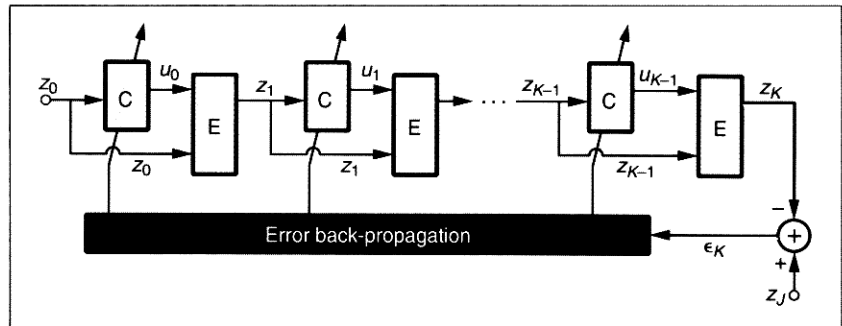

Figure 6. Training the controller with backpropagation (C = controller; E = emulator).

Figure 7. Example of a truck backup sequence

Figure 6. Training the controller with backpropagation (C = controller; E = emulator).

Figure 7. Example of a truck backup sequence

reduced by 5% to 8%; wear and tear on the furnace and the electrodes is reduced by about 20%; the power factor on the input power lines is brought closer to 1; and the daily throughput of steel is increased by 10%. The neural controllers are being installed by Neural Applications Corp. just as quickly as they can be produced. These improvements are reportedly worth millions of dollars per year per furnace.

The Chemical Process Industry Pavilion Technologies, Inc. of Aus-

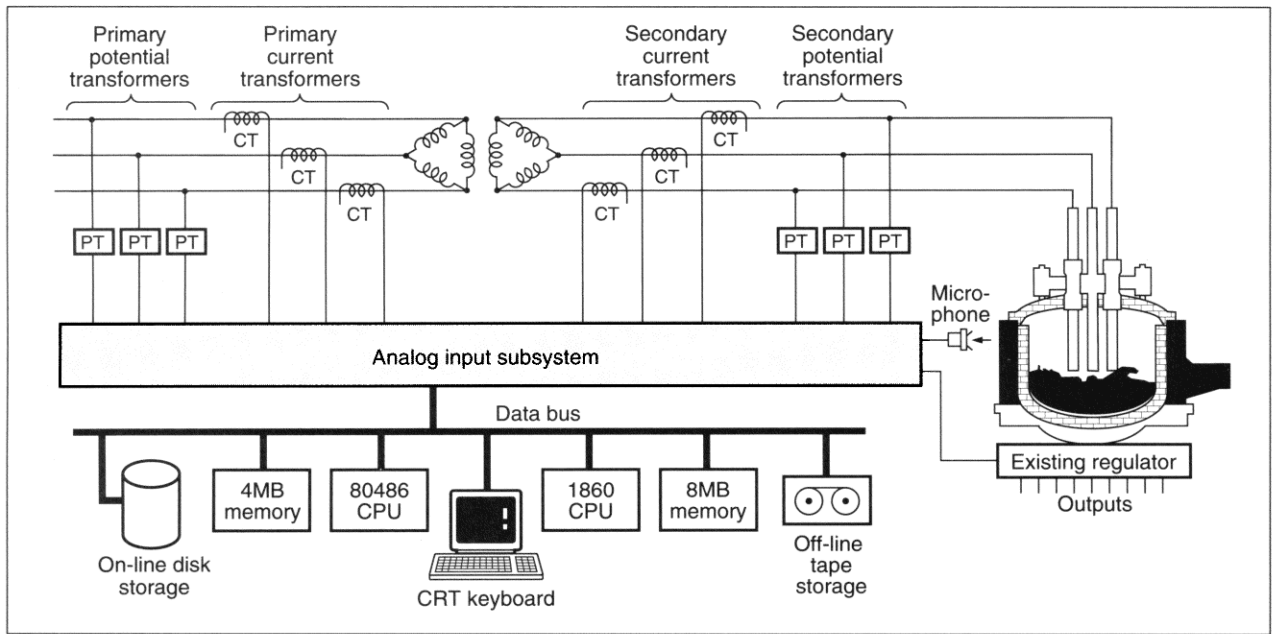

Figure 8. Arc furnace data acquisition system. *Source:* Courtesy of Bill Staib

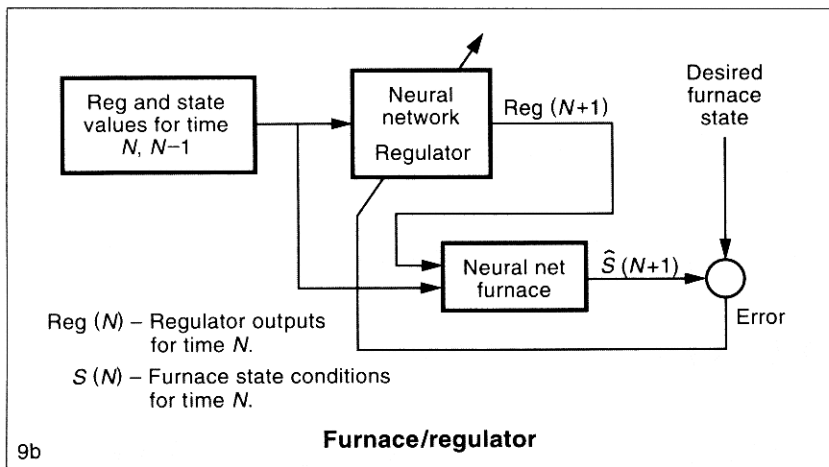
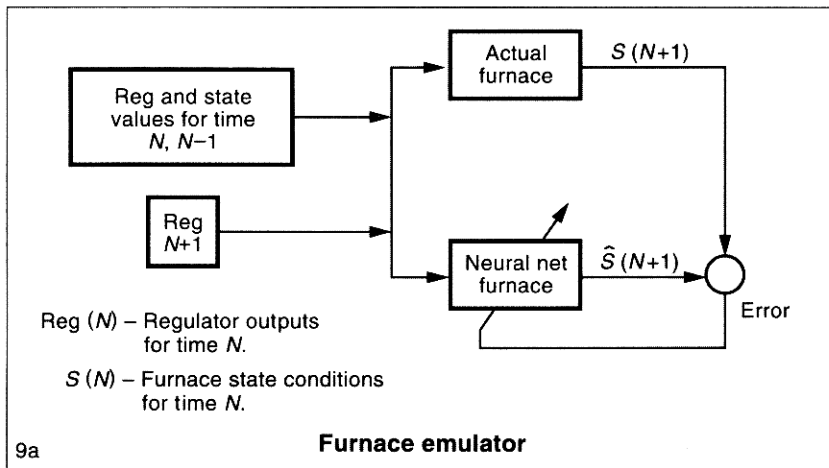

Figure 9. Block diagrams of a. furnace emulator; b. furnace/regulator. *Source:* Courtesy of Bill Staib

tin, Tex., has embedded neural networks and fuzzy logic into their Process Insights package for chemical manufacturing and control applications [4]. In this package, the user takes historical process data and uses it to build a predictive model of plant behavior. The model is then used to change the control setpoints in the plant to optimize behavior. Pavilion Technologies is a spin-off of MCC, where the original work was done in 1989 to 1990 by John Havener of Texas Eastman and Jim Keeler of MCC/Pavilion Technologies. In the original application conducted at the Texas Eastman Facility, Longview, Tex., neural networks in the Process Insights package produced setpoint changes that reduced by one-third the requirement of an expensive chemical additive needed to remove byproduct impurities during production. The facility produces plastics and chemical intermediates such as aldehydes and olefins. Since that work was completed, the technology and Pavilion's Process Insights software has been used in nearly 200 real-world applications, including modeling and optimization of distillation columns, modeling and control of plastics production, modeling and control of impurity levels in boil-

ers. These applications have generated tremendous paybacks, with savings of some applications totalling millions of dollars per year in single-unit production facilities. Texas Eastman, a division of Eastman Kodak, has been so satisfied with the results achieved by neural networks in the Process Insights package that they are currently encouraging the use of neural networks throughout their Longview plant. The success of the program is described in the April 29, 1993 issues of the company newsletter *Texas Eastman News*.

In making these applications, the first step is plant modeling or plant emulation. Typically, the plant has many inputs (such as pressures, temperatures, flow rates, and feed-stock characteristics) and one or more output parameters (such as yield, impurity levels, variance). In Figure 10 an

adaptive neural network is used to model an unknown plant (i.e., to learn the plant's dynamics from historical data).

Once the plant emulator converges, it can be used to train the neural net controller. Figure 11 shows how this is done. The error vector is the difference between the plant output vector and the desired-state vector. This error is backpropagated through the neural plant model to provide error signals for the adaptation of the weights of the controller. The controller weights are adapted by the backpropagation algorithm to minimize the sum of squares of the components of the error vector. Pavilion uses fuzzy logic in its Process Insights package to establish constraints on some of the controlled variables.

In most practical cases, it is not

possible to use a controller as simple as that shown in Figure 11. This is because almost all physical plants have internal dynamics. The plant's response to a control signal depends on both the current input to the plant and the current state of the plant. Any actions by the controller must therefore consider the state of the plant as well as its current input. A common solution involves incorporating tapped delay lines at the emulator and controller inputs to allow both networks to form internal representations of the present state. With tapped delay lines incorporated, Figure 11 then describes an increasingly popular form of open-loop control called nonlinear adaptive inverse control. Another approach is to incorporate one or more feedback loops in the system to create a dynamic system like the truck

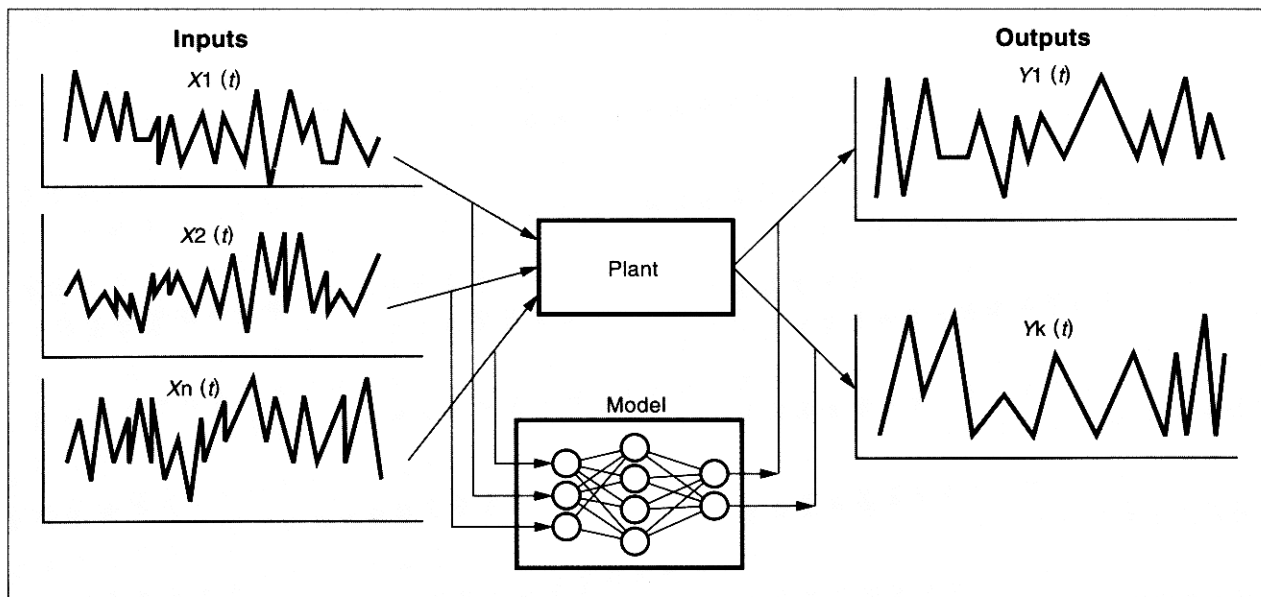

Figure 10. Adaptive plant emulation. Source: Courtesy of Jim Keeler

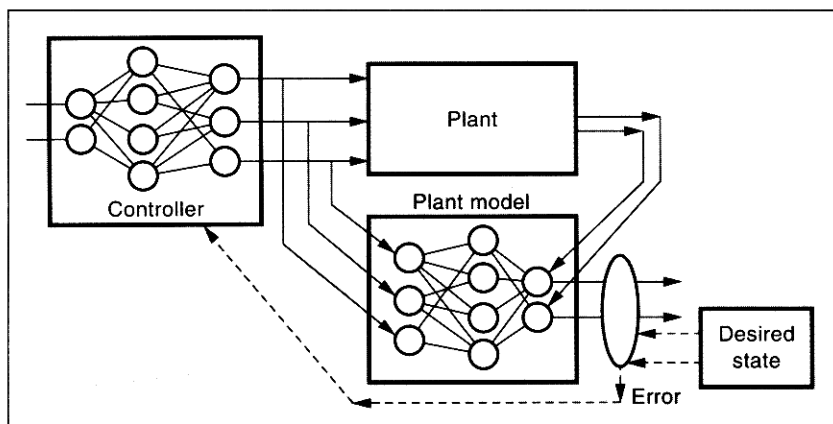

Figure 11. Using the plant model or emulator for backpropagation of error for training the neural controller. Source: Courtesy of Jim Keeler

backer. The controller can then be trained by backpropagation-through-time. Rather than simply using backpropagation to train the emulator as done with the truck backer, some closed-loop systems use backpropagation-through-time for this purpose as well [30].

In Process Insights, the relationship between the control history and the plant's state variables is determined by using measured states to train a dynamic state estimator [13]. The state estimator is then added to Figure 11 between the controller and the memoryless emulator. Memory is also added to the controller, which is trained by backpropagating error signals through the emulator and state estimator.

It is interesting to compare Figures 6, 9, and 11. Very similar things are going on in the vehicle control system (the truck backer), in the arc furnace control system, and in the chemical process control system. An emulator is made of the process to be controlled, and the controller is adapted by backpropagating the system error through the emulator. This is a very powerful idea, and it leads to useful applications. The reader should be aware however that this is not the only means of neural control. Other approaches include radial basis functions, reinforcement learning, and CMAC for problems such as process control, robotic actuator control, and vehicular control [34].

Conclusion

Neural network architectures will probably never be able to compete with conventional techniques at performing precise and well-defined numerical operations such as matrix inversions or Fourier transforms. However, there are large classes of problems that appear to be more amenable to solution by neural networks than by other available techniques. These tasks often involve ambiguity, such as that inherent in handwritten character recognition. Problems of this sort are difficult to tackle with conventional methods such as matched filtering or nearest-neighbor classification, in part because the metrics used by the brain to compare patterns may not be very

closely related to those chosen by an engineer designing a recognition system. Likewise, because reliable rules for recognizing a pattern are usually not at hand, fuzzy logic and expert system (ES) designers also face the difficult and sometimes impossible task of finding acceptable descriptions of the complex relations governing class inclusion. In trainable neural network systems, these relations are abstracted directly from training data. Moreover, because neural networks can be constructed with numbers of inputs and outputs ranging into the thousands, they can be used to attack problems that require consideration of more input variables than could be feasibly utilized by most other approaches. It should be noted, however, that neural networks will not work well at solving problems for which sufficiently large and general sets of training data are not obtainable.

Other tasks, such as those performed by VeriFone's Onyx Check Reader and by event detectors in particle colliders, can be solved successfully using more conventional approaches, but neural networks help provide solutions which result in less hardware. Faster response times, lower costs, and quicker design cycles. Several applications are now taking advantage of the high speeds and low costs of various neural network chips.

Perhaps the most important advantage of neural networks is their adaptivity. Neural networks can automatically adjust their parameters (weights) to optimize their behavior as pattern recognizers, decision makers, system controllers, predictors, and so forth. Self-optimization allows the neural network to "design" itself. The system designer first defines the neural network architecture, determines how the network connects to other parts of the system, and chooses a training methodology for the network. The neural network then adapts to the application. Adaptivity allows the neural network to perform well even when the environment or the system being controlled varies over time. There are many control problems that can benefit from continual nonlinear modeling and adaptation. Neural networks,

such as those used by Pavilion in chemical process control, and by Neural Applications Corp. in arc furnace control, are ideally suited to track problem solutions in changing environments. Additionally, with some "programmability," such as the choices regarding the number of neurons per layer and number of layers, a practitioner can use the same neural network in a wide variety of applications. Engineering time is thus saved.

Another example of the advantages of self-optimization is in the field of ES. In some cases, instead of obtaining a set of rules through interaction between an experienced expert and a knowledge engineer, a neural system can be trained with examples of expert behavior. The neural net becomes, in a sense, a trainable ES. Although it would implement rules, the actual rules implemented would not be apparent. The system designer would not be dealing with rules explicitly. On the other hand, if precise and complete rules are available or obtainable, then one would do best to use a classical ES.

This article has described only a small fraction of the commercial, industrial, and scientific applications of neural networks that exist today. The list is long and impressive and growing rapidly. There is no way to predict how widespread use of the technology will eventually become. However, based on the current extent of the field, and the rapidity of its growth, it seems reasonable to expect that before the turn of the century, neural networks will be a household word and a part of everyday life. **G**

References

1. *AI Expert*. Loudspeaker diagnosis. 5, 6 (June 1990), 71.
2. Andes, D., Widrow, B., Lehr, M., and Wan, E. MRIII: A robust algorithm for training analog neural networks. In *Proceedings of the International Joint Conference on Neural Networks*. Vol. 1. Erlbaum, Hillsdale, N.J., pp. 533-536.
3. *Economist*. Tilting at chaos. (Aug. 15, 1992), 70.
4. Ferguson, R.B. Chemical process optimization utilizing neural network systems. In *SICHEM '92* (Seoul, Korea). Erlbaum, Hillsdale, N.J., 1992.

5. Flam, F. Neural nets: A new way to catch elusive particles. *Science* 256, 5061 (May 29, 1992), 1282–1283.
6. Fuoichi, A. Neural networks: No zealots yet but progress being made. *Comput. Can.* 18, 2 (Jan. 20, 1992), 16.
7. Gill, T. and Shutt, J. Optimizing product formulations using neural networks. *Sci. Comput. Automat.* (Sept. 1992).
8. Hall, C. Neural net technology: Ready for prime time? *IEEE Expert* (Dec. 1992), 2–4.
9. Hammerstrom, D. Neural networks at work. *IEEE Spectr.* (June 1993), 26–32.
10. Hoffman, T. Don't choose technology without him. *Computerworld* 27, 4 (Jan. 25, 1993), 27.
11. Johnson, R.C. What is cognitive computing?: Intelligence from nature conquers tough programming problems. *Dr. Dobbs J.* 18, 2 (Feb. 1993), 18–22.
12. Kane, L.A. How combined technologies aid model-based control. *Hydrocarbon Proc.* (May 1993), 23.
13. Keeler, J.D. Prediction and control of chaotic chemical reactions via neural network models. In *Proceedings of the 1993 Conference on Artificial Intelligence in Petroleum Exploration and Production* (Plano, Tex., May 19–22, 1993).
14. Kestelyn, J. Neural net for quality control. *AI Exp.* 5, 10 (Oct. 1990), 71.
15. Nguyen, D. and Widrow, B. The truck backer-upper: An example of self-learning in neural networks. In *Proceedings of the International Joint Conference on Neural Networks*. Vol. II. Erlbaum, Hillsdale, N.J., pp. 357–363.
16. Pallett, T.J. and Ahmad, S. Real-time neural network control of a miniature helicopter in vertical flight. In *Proceedings of the Seventeenth International Conference on Applications of Artificial Intelligence in Engineering—AIENG/92* (Waterloo, Ontario, Canada, 1992).
17. *PC AI*. Product guide: Fuzzy logic—neural networks. (Mar./Apr. 1993), 52–56.
18. Port, O. Sure, it can drive, but how is it at changing tires. *Bus. Week* (Mar. 2, 1992), 98–99.
19. Rennie, J. Cancer catcher: Neural net catches errors that slip through pap tests. *Sci. Am.* 262, 5 (May 1990), 84.
20. Rumelhart, D.E. Theory to practice: A case study—recognizing cursive handwriting. In *Proceedings of the Third NEC Research Symposium*. SIAM, Philadelphia, Pa., 1993.
21. Rumelhart, D.E., Hinton, G.E., and Williams, R. J. Learning internal representations by error propagation. In *Parallel Distributed Processing*. Vol. 1. The MIT Press, Cambridge, Mass., 1986, chapt. 8.
22. Sandler, D.G., Barrett, T.K., Palmer, D.A., Fugate, R.Q., and Wild, W.J. Use of a neural network to control an adaptive optics system for an astronomical telescope. *Nature* 351 (May 1991), 300–302.
23. Schuon, M. New technology chips away at noise. *New York Times* (Jan. 27, 1991). National Edition, sec. 1, p. 30.
24. Schwartz, E.I. Where neural networks are already at work: Putting AI to work in the markets. *Bus. Week* (Nov. 2, 1992), 136–137.
25. Schwartz, E.I. and Treece, J.B. Smart programs go to work: How applied-intelligence software makes decisions for the real world. *Bus. Week* (Mar. 2, 1992), 97–105.
26. Shandle, J. Neural networks are ready for prime time. *Elect. Des.* 41, 4 (Feb. 18, 1993), 51–58.
27. Shea, P.M. and Lin, V. Detection of explosives in checked airline baggage using an artificial neural system. In *Proceedings of the International Joint Conference on Neural Networks*. Vol. II (Washington, D.C., June 1989), pp. 31–34.
28. Staib, W.E. and Staib, R.B. The intelligence arc furnace controller: A neural network electrode position optimization system for the electric arc furnace. In *The International Joint Conference on Neural Networks*. IEEE, New York, 1992.
29. Weinstein, J.N., Kohn, K.W., Grever, M.R., Viswanadhan, V.N., Rubinstein, L.V., Monks, A.P., Scudiero, D.A., Welch, L., Koutsoukos, A.D., Chiausa, A.J., and Paull, K.D. Neural computing in cancer drug development: Predicting mechanism of action. *Science* 258, 16 (Oct. 1992), 447–451.
30. Werbos, P.J. Neural networks, system identification, and control in the chemical process industries. In *Handbook of Intelligent Control*. Van Nostrand Reinhold, New York, 1992.
31. Widrow, B. and Lehr, M.A. Thirty years of adaptive neural networks: Perceptron, madaline, and backpropagation. In *Proceedings of IEEE 78*, 9 (Sept. 1990), pp. 1415–1442.
32. Widrow, B. and Stearns, S.D. *Adaptive Signal Processing*. Prentice-Hall, Englewood Cliffs, N.J., 1985.
33. White, D.A. and Sofge, D.A., Eds. *Handbook of Intelligent Control*. Van Nostrand Reinhold, New York, 1992.
34. Wright, D.P. and Scofield, C.L. Divide and conquer. *BYTE* (Apr. 1991), 207–210.

About the Authors:

BERNARD WIDROW is professor of electrical engineering at Stanford University. He does research and teaching in the fields of digital signal processing, adaptive signal processing, adaptive control systems, pattern recognition, and neural networks. He is coinventor of the LMS algorithm and the neural element ADALINE and various MADALINE networks.

DAVID E. RUMELHART is professor of psychology at Stanford University. His research has focused on how people learn complex skills such as reading, and how that knowledge is represented in the mind. He is coauthor of the well-known 2-volume set of connectionist texts, *Parallel Distributed Processing*.

MICHAEL A. LEHR is a doctoral candidate in electrical engineering at Stanford University. His research involves the application of second-order training techniques to large neural networks.

Authors' Present Addresses: Bernard Widrow and Michael Lehr can be reached at Stanford University Department of Electrical Engineering, Durand Bldg., Stanford, CA 94305-4055. David Rumelhart can be reached at Stanford University Department of Psychology, Bldg. 420 Room 414, Stanford, CA 94305-2130.

Support for this work was provided by the National Science Foundation under grant NSF IRI 91-12531, the ONR under contract no. N00014-92-J-1787, the EPRI under contract RP:8010-13, and the Department of the Army Belvoir RD&E Center under contract no. DAAK70-92-K0003. permission

Permission to copy without fee all or part of this material is granted provided that the copies are not made or distributed for direct commercial advantage, the ACM copyright notice and the title of the publication and its date appear, and notice is given that copying is by permission of the Association for Computing Machinery. To copy otherwise, or to republish, requires a fee and/or specific permission.

© ACM 0002-0782/94/0300 \$3.50